

## PRODUCT INTRODUCTION

The Bianco NXT Summit Series Drive Controller Kits are an all-in-one solution designed to achieve advanced control, enhanced protection and optimal energy efficiency with the Bianco NXT range of Variable Frequency Drives.

Featuring the latest touch-screen technology and an intuitive user-friendly menu, these kits provide easy access to all the information you need.

SUMMIT SERIES VMS solutions are designed for performance, reliability and ease of use.



Image illustrative only



## INCLUDES

- Galvanised triple-pump base
- 3 x VMS Pumps
- 3 x NXT Drives (Variable Frequency Drive)
- 4-20mA/10bar Pressure Transducer
- Stainless Steel Counter Flanges
- Gaskets to suit Counter Flanges
- Watermarked Spring Check Valve
- Manifold (304 Stainless Steel)
- 30bar Liquid-filled Pressure Gauge
- Outlet-side SS Isolation Valve
- BPT-18 10bar-rated Pressure Tank with 304 SS 25mm isolating valve

## PUMP TECHNICAL DATA

<b>RATED FLOW [M3/H]</b>	8 m <sup>3</sup> /hr per pump
<b>MAX. FLOW – PUMP SET</b>	36 m <sup>3</sup> /hr
<b>MAX. HEAD – PUMP SET</b>	86.8 m
<b>WORKING AIR TEMP</b>	0°C – 40°C
<b>LIQUID TEMPERATURE</b>	-15°C – 120°C
<b>HIGHEST EFFICIENCY</b>	63.5%
<b>MAXIMUM PUMP PRESSURE</b>	33 bar
<b>NET WEIGHT (KG)</b>	52.6 kg

<b>RATED VOLTAGE/CURRENT</b>	3ph 230V +10% -6% 10.5A
<b>MOTOR POWER (KW)</b>	3.0kW 2-pole
<b>MOTOR IP RATING</b>	IP55
<b>MOTOR INSULATION</b>	Class F
<b>MOTOR EFFICIENCY STD</b>	I.E.3
<b>MOTOR EFFICIENCY</b>	87.1%
<b>COS Ø</b>	0.87
<b>MECHANICAL SEAL</b>	SVH-L-16
<b>PUMP FLANGE SIZE</b>	DN40
<b>MANIFOLD OUTLET SIZE</b>	Dual 65mm / DN65 Flange

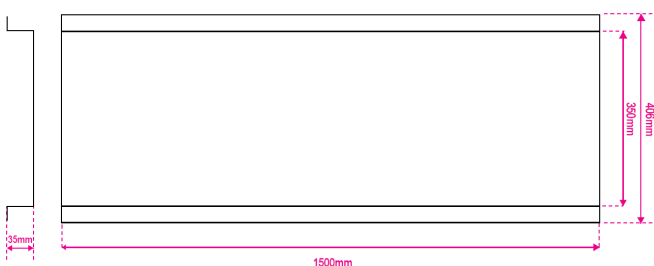

Base 1500 x 406mm x 35mm high

BIA-DRIVE1-37-240

## PRODUCT DETAILS



Single Phase 230VAC IN / Single Phase 230VAC OUT

## TECHNICAL DATA

INPUT VOLTAGE	1ph 220VAC ±15%
INPUT FREQUENCY	50/60Hz 5% fluctuations
OUTPUT VOLTAGE	1ph 230VAC
OUTPUT FREQUENCY	0 – 200Hz
OUTPUT RATING	17A / Nominal 3.7kW
SPEED HOLDING PRECISION	±1%
INGRESS PROTECTION	IP54
OPERATING TEMPERATURE	-10°C to +40°C

The NXT DRIVE Series are a range of pump-specific Variable Frequency Drives designed for the Australasian market with both the end-user and the technician in mind.

Featuring a full-colour, touch-screen interface for clear, concise system information, fault codes and protection notices, with a handy setup wizard so you're always in control. NXT DRIVE is both simple to set up and use.

Perfect for achieving constant pressure management of a single pump with advanced control, enhanced protection and optimal energy efficiency.

## FEATURES

- Control and protect pumps up to 3.7kW (17 Amps)
- Variable frequency control to achieve constant pressure control
- Minimise wasted energy and reduce the need for large pressure tanks
- 'Soft-start' with low motor start current
- Flow, pressure and current protections
- RS485 comms
- 25 plain-language fault messages
- Provides protection from dry run, high and low voltage, input and output short circuits, high and low water pressure, input and output phase failure, high temperature and sensor faults
- 24V, 10V and 5V supply circuits
- Digital and analogue (voltage or current) inputs
- Relay and analogue outputs
- Multi-functional terminals



### SINGLE PUMP HYDRAULIC CURVE

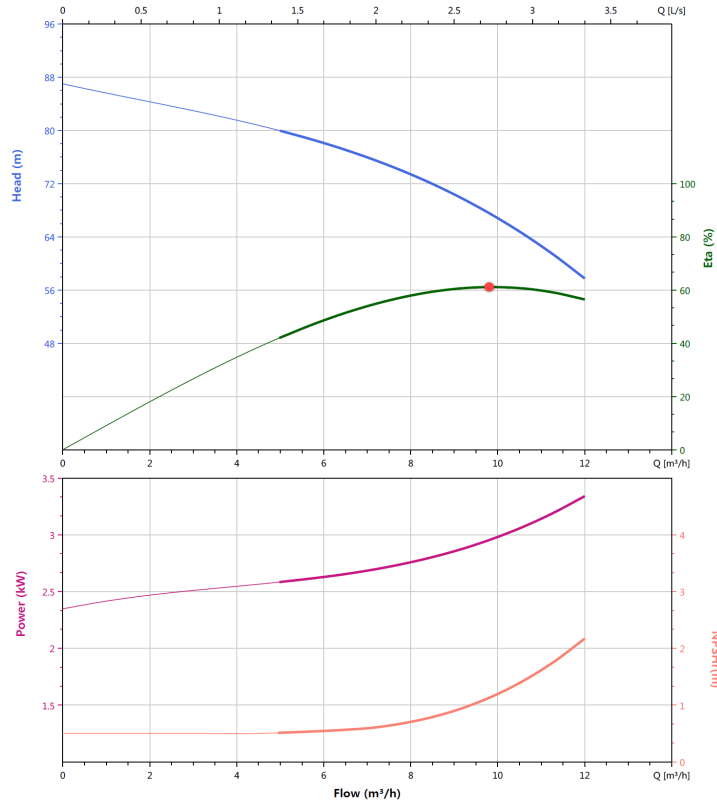

### VFD CURVE

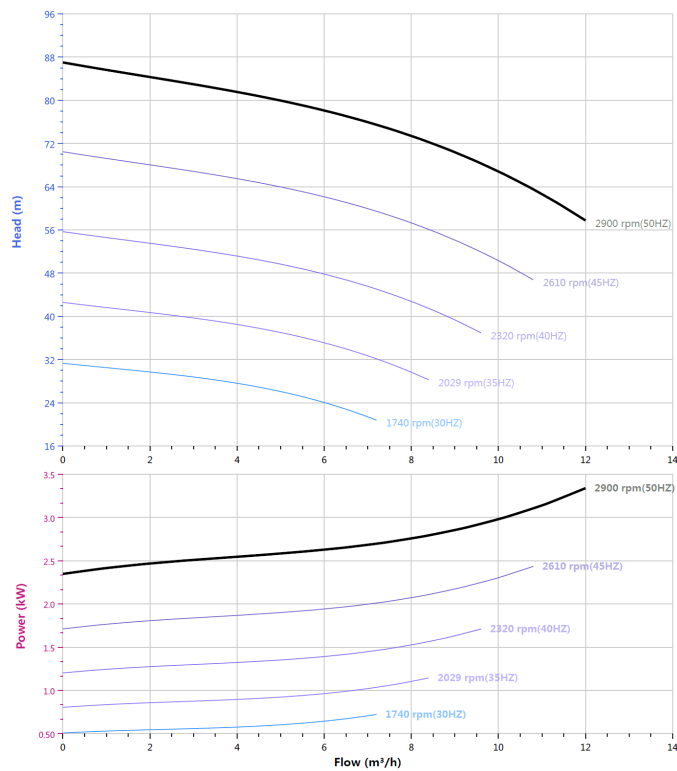

## TRIPLE PUMP HYDRAULIC CURVE

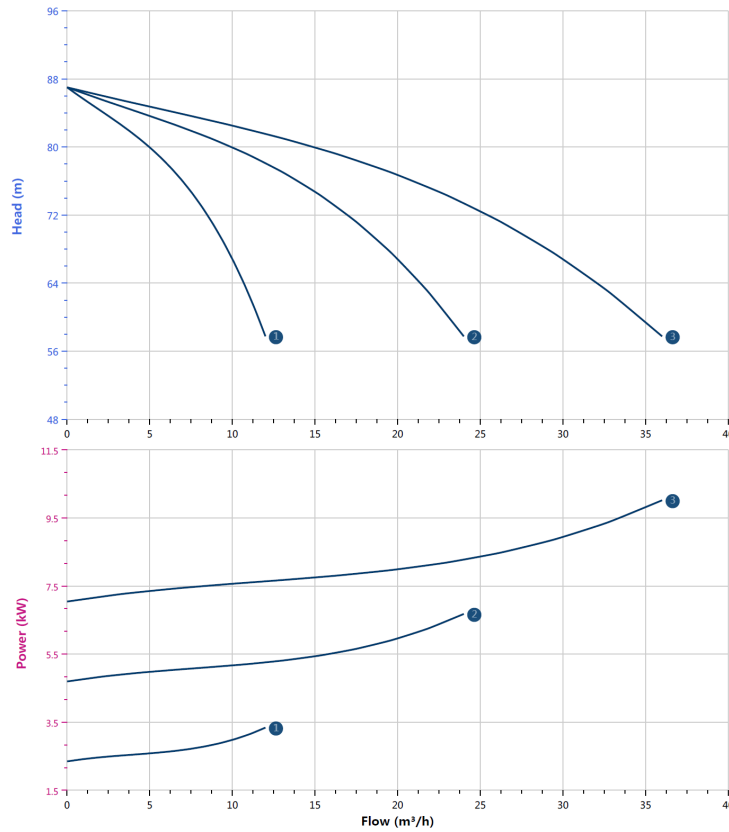

## CUTAWAY

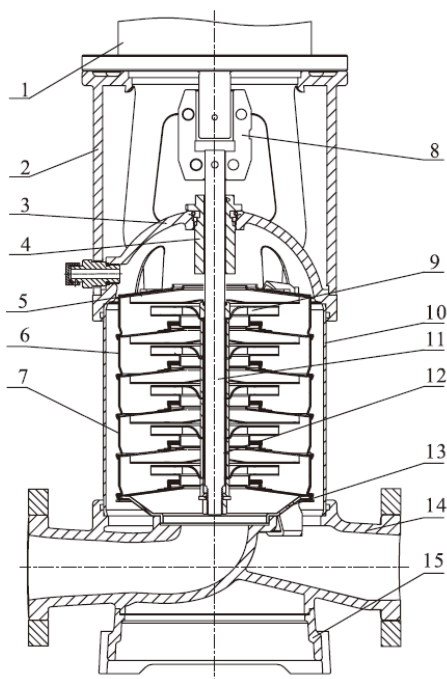

1	Motor	/
2	Bracket	Ductile Cast Iron
3	Seal Base	Stainless / Ductile Cast Iron
4	Mechanical Seal	SVH-L-16
5	Top Diffuser	Stainless Steel
6	Diffuser	Stainless Steel
7	Support Diffuser	Stainless Steel
8	Coupling	Stainless Steel
9	Impeller	Stainless Steel
10	Cylinder	Stainless Steel
11	Shaft	Stainless Steel
12	Intermediate Bearing	SiC / WC
13	Inducer	Stainless Steel
14	Inlet/Outlet Chamber	Stainless Steel / Ductile Cast Iron
15	Base	Ductile Cast Iron

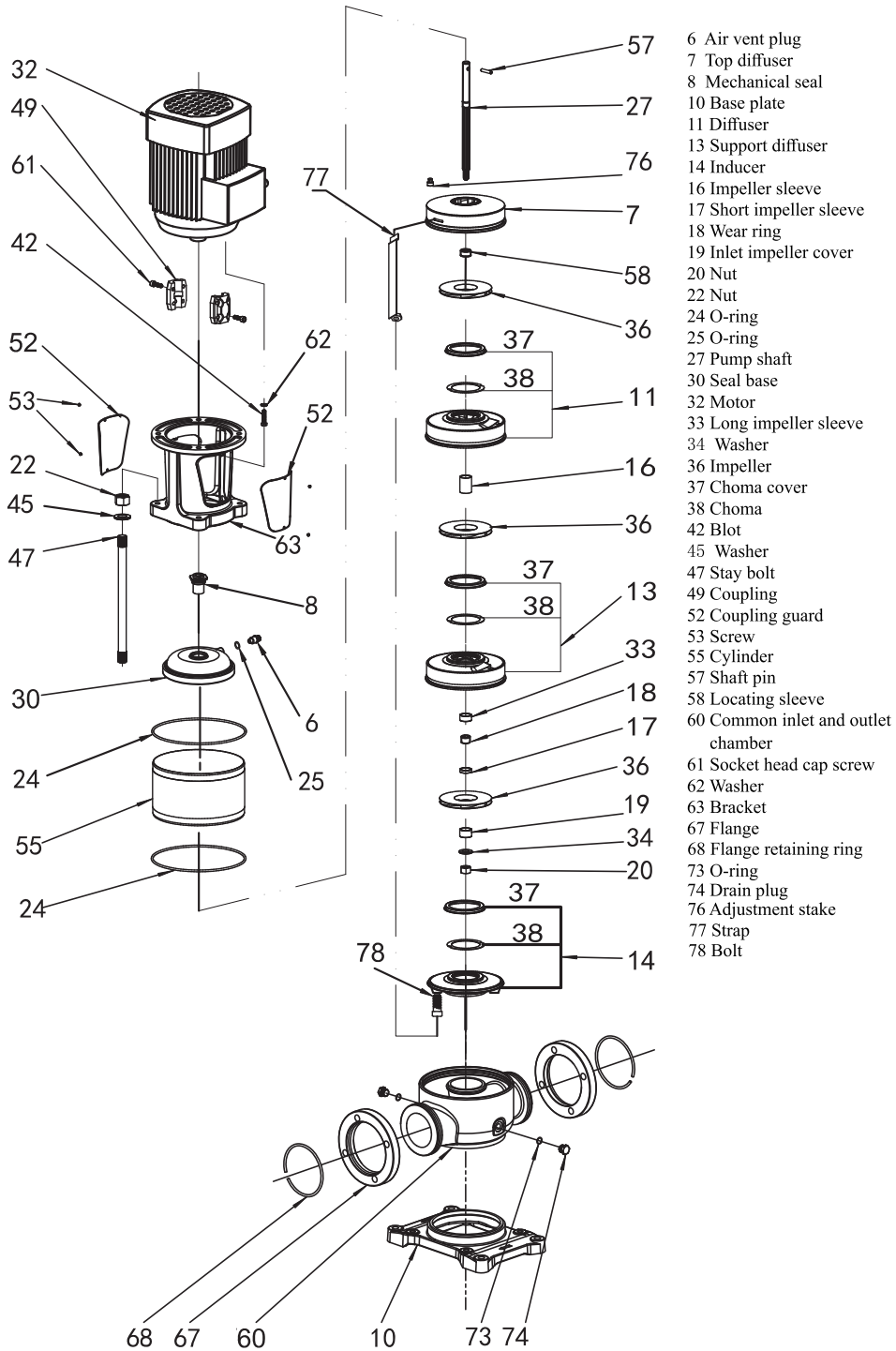

**WARRANTY / CERTIFICATIONS**

